

PRATICA MODULA MATRIX HT CTS



-20<ta<40°C

230Vac - 50/60Hz
216Vdc



Beghelli

www.beghelli.com
BEGHELLI S.p.A. - Via Mozzeghine 13/15 - località Monteveglio 40053 Valsamoggia (BO) - Tel. +39 051 9660411 - Fax +39 051 9660444 - N° Verde 800 626626



Per approfondimenti e aggiornamenti inquadra il codice QR sul prodotto
For further information and updates, scan the QR code on the product

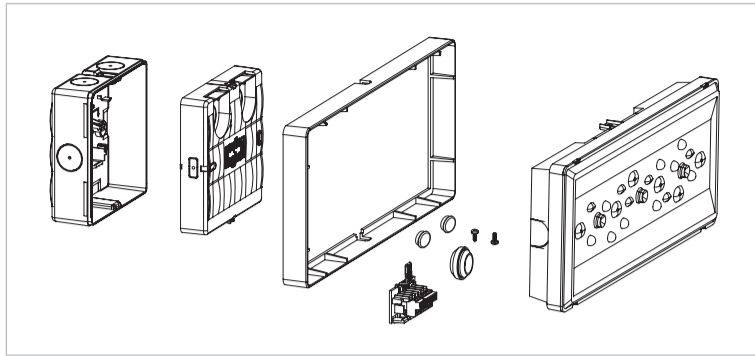
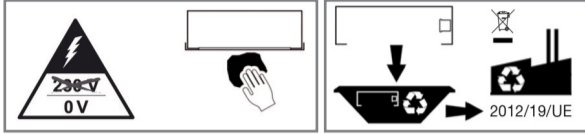

334.902.441 C

A MONTAGGI - MOUNTING

A1 EASY BOX basso - Low EASY BOX

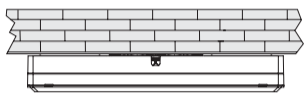

18598

(cornice per EASY BOX basso inclusa - frame for low EASY BOX included)

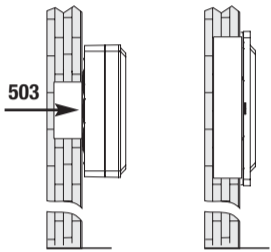

+ cod. 18580
scatola incasso -
flush-mounted box

A2 EASY BOX alto - High EASY BOX

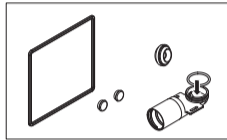

+ cod. 18592

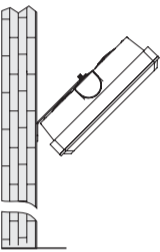

+ cod. 18590
staffa 45° - 45° bracket

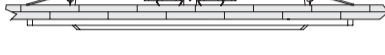

+ cod. 18586
staffa per controsoffitto - ceiling bracket

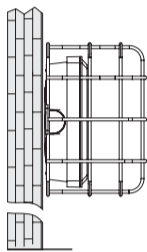

+ cod. 18591
griglia protettiva - protective grille



+ cod. 4323
kit binario trifase -
three-phase track kit

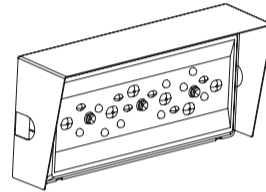

+ cod. 18597
tegola anti-pioggia - rainproof tile

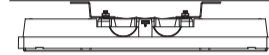

+ cod. 18587
staffa blindoluce -
blindoluce bracket

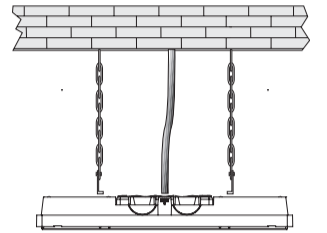

+ cod. 3723
gancio sospensione -
suspension hook

B INSTALLAZIONE EASY BOX - EASY BOX INSTALLATION

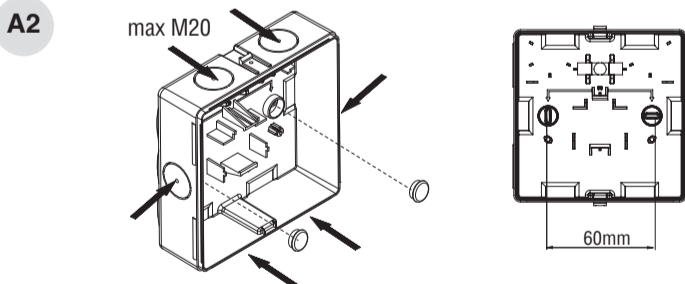
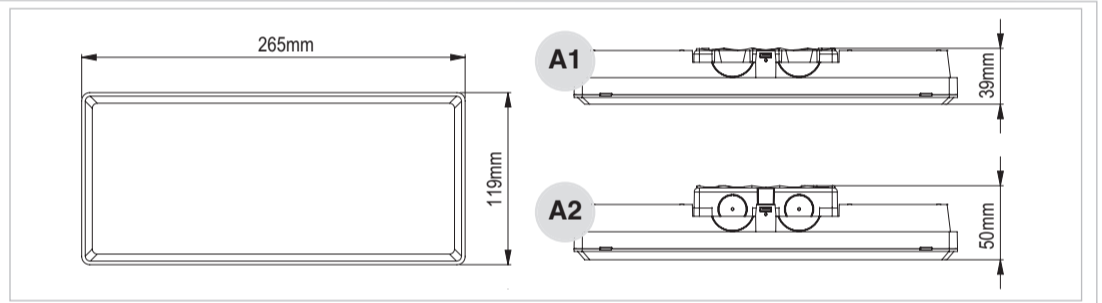
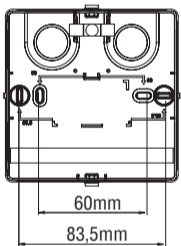
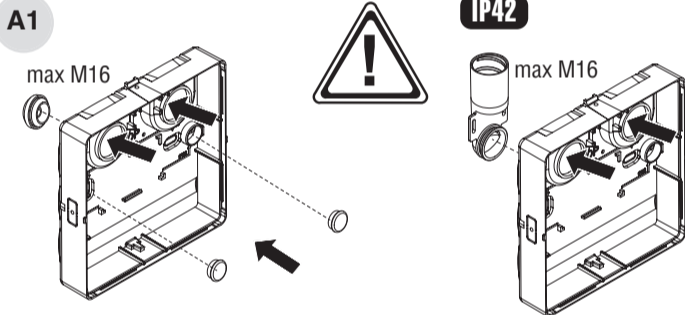

D SETTAGGI MANUALI - MANUAL SETTINGS

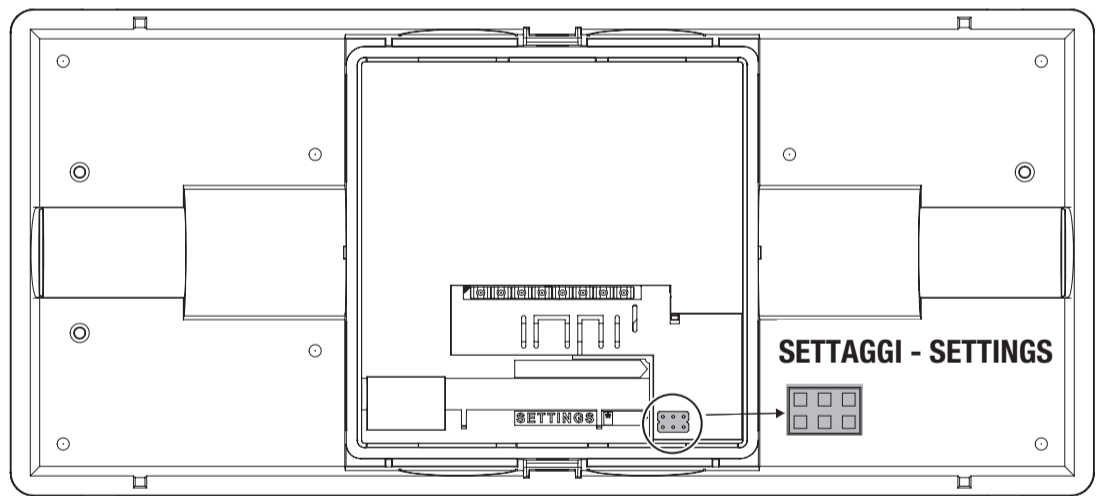

SETTAGGIO MANUALE OTTICA

MANUAL OPTIC SETTING



1 = TUTTO ACCESO (default)

1 = ALL ON (default)



2 = VIE DI ESODO parete

2 = EXODUS wall



3 = GRANDI AREE parete

3 = LARGE AREAS wall



4 = PLAFONE (GRANDI AREE / VIE DI ESODO)

4 = CEILING (LARGE AREAS / EXODUS)



5 = ALTO RISCHIO plafone

5 = HIGH RISK ceiling

SETTAGGIO MANUALE PERCENTUALE DI FLUSSO PRODOTTO

PRODUCT FLOW PERCENTAGE MANUAL SETTING



100% (default)



50%

C COLLEGAMENTO - CONNECTION

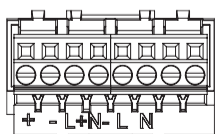

230Vac ±10%
216Vdc ±20%



Attenzione alla polarità dell'alimentazione in continua

Attention to the polarity of the DC power supply



Settaggio con App B.connect - Setting with App B.connect

A- Aprire App B.connect (scaricabile su App Store e Google Play).

B- Tramite il menu "lampada/Bluetooth" si accede alle impostazioni e "Configurazioni lampada":

- Settaggio ottica;
- Settaggio flusso luminoso;
- Reset



APERTURA COMUNICAZIONE VIA BLUETOOTH®

Alla prima alimentazione della lampada si attiva una finestra di programmazione di 2 ore.

N.B. Dopo le 2 ore il Bluetooth® si spegne.

COMMUNICATION OPENING VIA BLUETOOTH®

When the lamp is powered up for the first time, a 2-hour programming window is activated.

N.B. after 2 hours the Bluetooth® turns off.

A- Open App B.connect (available for download on the App Store and Google Play).

B- From the "Lamp/Bluetooth" menu you can access the settings and "Lamp configurations":

- Optical setting;
- Luminous flux setting;
- Reset



E CHIUSURA PRODOTTO - PRODUCT CLOSURE

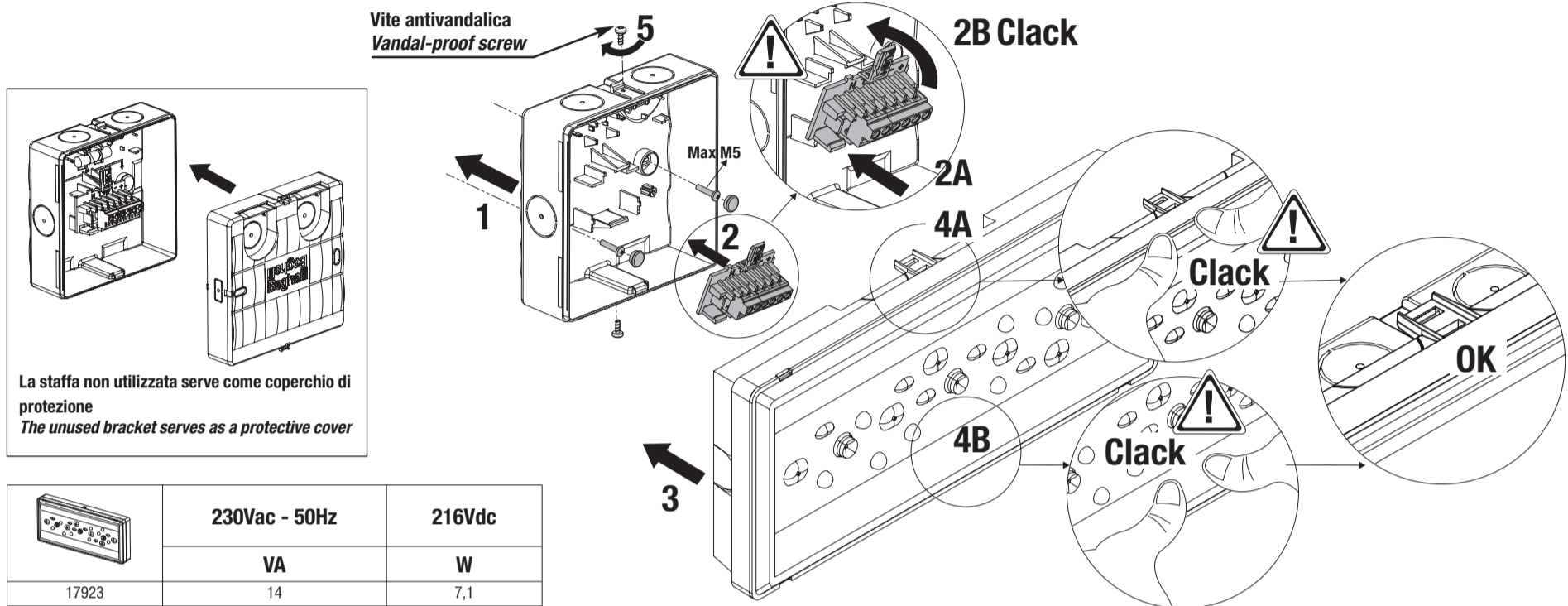

	230Vac - 50Hz	216Vdc
	VA	W
17923	14	7,1

MODULI CTS OPTIONAL - OPTIONAL CTS MODULES

- + COD 15059 LG24
- + COD 15060 LG230
- + COD 15061 LG EPS DALI

Per installazione ed uso consultare i manuali degli accessori.

Attenzione: accessori utilizzabili solo con easy box dedicata (solo versione "alta")

- + COD 15059 LG24
- + COD 15060 LG230
- + COD 15061 LG EPS DALI

For installation and use, consult the accessory manuals.

Attention: accessories that can only be used with the dedicated easy box ("high" version only)

AVVERTENZE - GARANZIA

- Questo apparecchio dovrà essere destinato solo all'uso per il quale è stato costruito. Ogni altro uso è da considerarsi improprio e pericoloso.
- La sorgente LED è di tipo non sostituibile. Per

eventuali riparazioni rivolgersi ad un centro di assistenza tecnica autorizzato e richiedere l'utilizzo di ricambi originali. Il mancato rispetto di quanto sopra può compromettere la sicurezza dell'apparecchio.

WARNINGS - GUARANTEE

- This device shall be used exclusively for the purpose for which it has been designed. Any other use is considered improper and therefore dangerous.

- LED source is not replaceable. Contact an authorised technical service centre for any repairs possibly required use only original spare parts. The lacked respect of the above conditions may compromise the safety of the device.

WARNUNG - GARANTIE

- Das Gerät ist ausschließlich für den Zweck, für den es hergestellt wurde, zu verwenden. Jede davon abweichende Verwendung wird als nicht zweckentsprechend und somit als gefährlich angesehen.

- Die LED-Quelle ist nicht auswechselbar. Für eventuelle Reparaturen kann ein autorisiertes Service-Center kontaktiert werden, um original-Ersatzteile anzufordern. Das Nichteinhalten der oben genannten Bestimmungen kann die Gerätesicherheit gefährden.

AVERTISSEMENTS - GARANTIE

- Cet appareil ne devra être destiné qu'à l'utilisation pour laquelle il a été construit. Tout autre utilisation est improprie et dangereuse.
- La source LED est de type non remplaçable. Pour éventuel réparations, s'adresser à un centre d'as-

sistance technique agréé et demander l'utilisation de pièces de rechange originales. Le non respect des indications susmentionnées peut compromettre la sécurité de l'appareil.

ADVERTENCIAS - GARANTÍA

- Este equipo tiene que ser usado sólo para la utilización para la que ha sido construido. Cualquier otro uso se considera impropio y peligroso.
- La fuente LED es de tipo no sustituible. Para

posibles reparaciones, dirigirse a un centro de asistencia técnica autorizado y solicitar el uso de recambios originales. La falta de respeto de cuanto indicado anteriormente puede perjudicar la seguridad del aparato.

ADVERTÊNCIAS - GARANTIA

- Este aparelho deverá ser destinado somente ao uso para o qual foi construído. Qualquer outro tipo de uso será considerado impróprio e perigoso.

- A fonte LED não pode ser substituída. Para eventuais reparações dirigir-se a um centro de assistência técnica autorizado e pedir a utilização de peças sobressalentes e acessórios originais. O desrespeito das regras supra-citadas pode comprometer a segurança do aparelho.

WAARSCHUWINGEN - GARANTIE

- Dit apparaat moet alleen daarvoor gebruikt worden waarvoor het gemaakt is. Elk ander gebruik moet als verkeerd en daarom gevaarlijk beschouwd worden.

- Kildelysdioden er av typen som ikke kan skiftes ut. For eventuelle reparaties, contact op met een geautoriseerd service center en verzoeken het gebruik van originele reserveonderdelen. Het niet in acht nemen van de hierboven beschreven richtlijnen kan de veiligheid van het apparaat in gevaar brengen.

ADVARSLER - GARANTI

- Dette armatur må udelukkende anvendes til det brug, som det er blevet konstrueret for. Enhver andet brug må betragtes som ukorrekt, og derfor farligt.

- LED-kilden er ikke udskiftelig. For eventuelle reparationer, kontakt et autoriseret servicecenter og kræve brug af originale reservedele. Manglende overholdelse af ovennævnte regler kan skade produktet.

VARNINGAR - GARANTI

- Den här apparaten får bara användas i avsett syfte. All annan användning är att anses som oriktig och därför farlig.
- Kontrolllampans källa är inte utbytbar. För alla

reparationer, kontakta auktoriserad teknisk service och beställ originaldelar från tillverkaren. Försummad hänsyn till ovanstående kan innebära risker för apparatens säkerhet.

MERKNADER - GARANTI

- Denne armaturen må kun benyttes til det formålet den er konstruert for. Enhver annen bruk er å regne som feilaktig og dermed farlig.
- De LED-bron is van het niet vervangbare type.

Ved eventuelle reparasjoner, ta kontakt med autorisert verksted eller installatør. Slike utskiftinger krever dessuten bruk av originale deler. Manglende etterfølgelse av det ovenfor beskrevne kan sette armaturens sikkerhet på spill.

UPOZORNĚNÍ - ZÁRUKA

- Toto svítidlo může být použito pouze k účelu, pro nějž bylo vyrobeno. Jakékoli jiné použití bude považováno za nevhodné a tím také nebezpečné.

- LED zdroj není vyměnitelný. Pro případné opravy se obraťte na autorizované servisní středisko, které používá pouze originální náhradní díly. Nerespektování výše uvedených podmínek může ohrozit bezpečnost zařízení.

WARUNKI - GWARANCJA

- Urządzenie powinno być stosowane wyłącznie do celów do jakich zostało zaprojektowane. Każde inne zastosowanie jest niewłaściwe a przez to i niebezpieczne.

- Niewymienialne źródło LED. Proszę skontaktować się z działem serwisowym producenta przed przystąpieniem do naprawy. Zaleca się stosowanie oryginalnych części zamiennych. Nieprzestrzeganie powyższych zaleceń może być niebezpieczne.

OPOZORILO - GARANCIJA

- Ta naprava se lahko uporablja samo za namene, za katere je bila zasnovana. Kakršnakoli druga uporaba se smatra kot neprimerna in posledično nevarna.

- LED vir ni zamenljiv. V primeru okvare ali naročila originalnih delov kontaktirajte pooblaščenega serviserja. Neupoštevanje zgornjih pogojev lahko ogrozi varnost naprave.