



Downlight System

DWL 24W 75° C90 IP54 BI RD 3K

Beghelli
IDEE PIENE DI VITA

Codice ordine 40365

EAN 8002219897022



Specifiche tecniche

Potenza assorbita	24 W, 22 W, 20 W, 18 W
Tipo di tensione di alimentazione	AC
Tensione alimentazione (AC)	230 Vac
Temperatura ambiente (min)	-20 °C
Temperatura ambiente (max)	40 °C
Classe di isolamento	II
CCT tonalità luce	3000 K
Grado di protezione ottica	IP54/IP20
Numero LED	1
Corrente di uscita (max)	600
Rischio fotobiologico	RG0
Angolo fascio luminoso	75 °
Stabilità colore	SDCM3
Colore riflettore	Bianco
CRI Resa cromatica	>90
Diametro	125 mm
Tipo driver	RD
Efficienza	110 lm/W, 110 lm/W, 110 lm/W, 110 lm/W
Frequenza (max)	60 Hz
Frequenza (min)	50 Hz
Res. filo incandescente	850 °C - 30s.
Corrente Inrush	5,88 A
Tempo di transizione Inrush	0,05
Efficienza ottica	100%, 100%
Flusso apparecchio	2640 lm, 2420 lm, 2200 lm, 1980 lm
Installazione	Incasso, Incasso in Controsoffitti
Range tensione alimentazione (max)	253 V
Range tensione alimentazione (min)	207 V

Installazione e applicazioni

Ambiente	Uffici
Applicazione	Uffici, Hotel, Scuole

Specifiche meccaniche

Altezza	117 mm
Lunghezza di taglio	110 mm
Materiale corpo	Alluminio pressofuso
Colore corpo	Bianco
Materiale riflettore	Alluminio Verniciato Bianco
Grado di protezione vano alimentazione	IP20

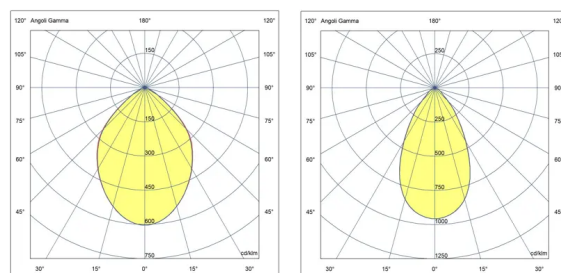
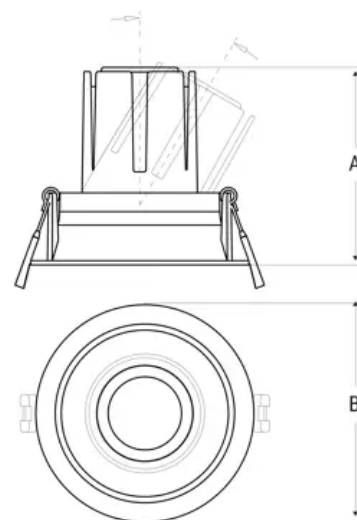

Grado di protezione IP	IP54/IP20
Grado di protezione IK	IK05

Certificati e normative

UK SI 2021 No. 1095, REG.
 2019/2020(EU), EN IEC 55015:2019 +
 A11:2020, EN IEC 61000-3-2 :2019, EN
 61000-3-3:2013, EN 61547:2009, EN
 62471:2008, EN IEC 60598-1:2021, EN
 60598-2-2:2012, EN 62493:2010

Accessori



40477
DOUBLE FILTER 24W



70059
KIT CAVETTO DI SICUREZZA



40480
ADAPTER RING 24W 110 TO
220MM



40461
RIF ROUND 24W TITANIUM



40469
OVAL FILTER 24W



40465
HONEYCOMB 24W



40473
NARROW FILTER 24W

Accessori inverter



15080
MODULO DALI SLIM



19359
INV P&L LED SE/SA 3H 20-
60V



19358
INV P&L LED SE/SA 1H 20-
60V



15037
MODULO LGFM



15079
MODULO LG SLIM



19398
INV UNIV AT RM 5W 20-240V



19399
INV UNIV CT 5W 20-240V