

EXIT CT 60m

0<ta<40°C

230V-50Hz



Beghelli

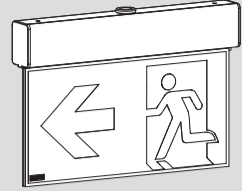

Per approfondimenti e aggiornamenti inquadra il codice QR sul prodotto
For further information and updates, scan the QR code on the product

www.beghelli.com
BEGHELLI S.p.A. - Via Mozzeghine 13/15 - località Monteveglio 40053 Valsamoggia (BO) - Tel. +39 051 9660411 - Fax +39 051 9660444 - N° Verde 800 626626

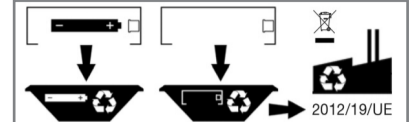
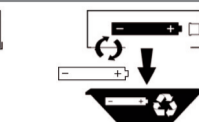
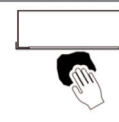
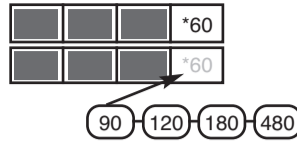

334.902.360 B

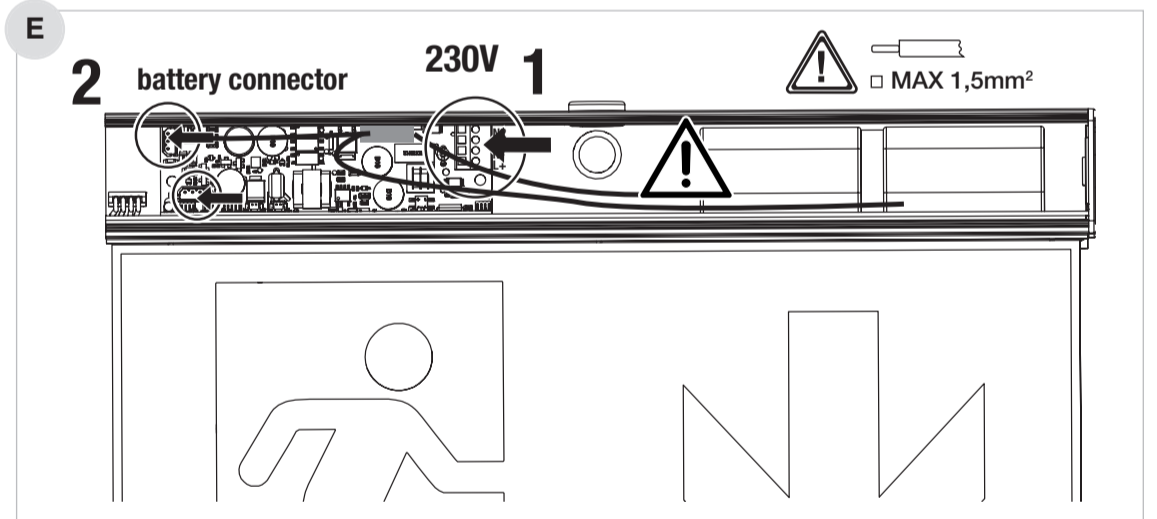
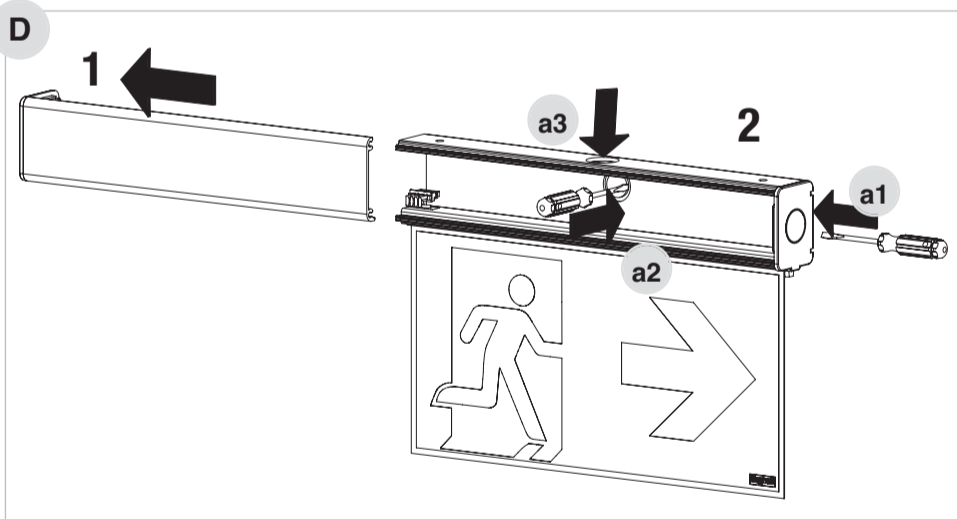
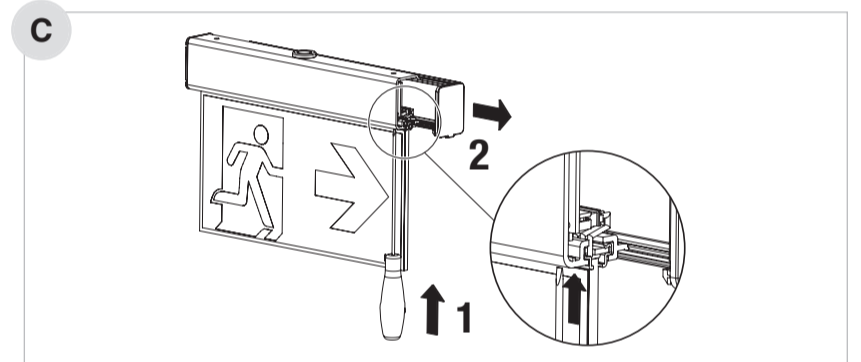
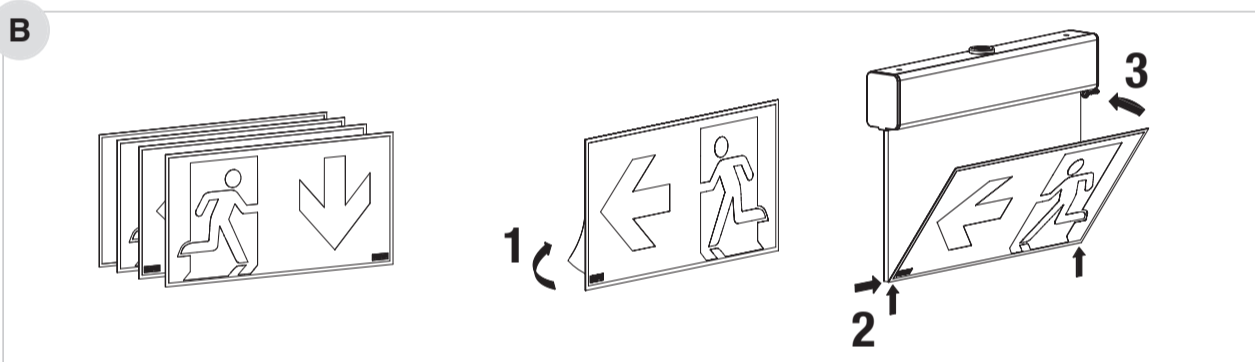
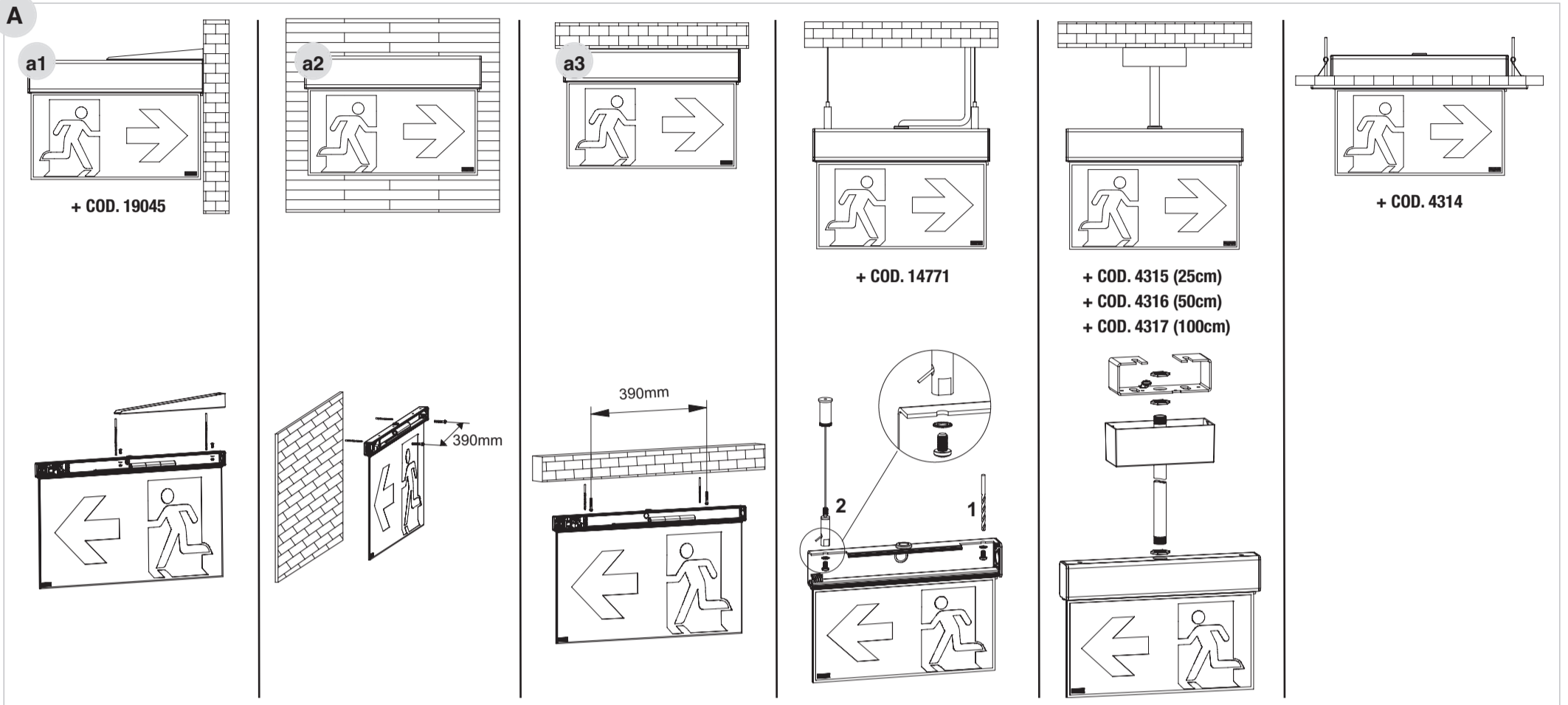

Cablaggio con Infinity mode (emergenza locale) disattivato - Cablaggio SE/SA Wiring with Infinity mode (local emergency) deactivated - Wiring SE/SA

Cablaggio con Infinity mode attivato Wiring with Infinity mode activated

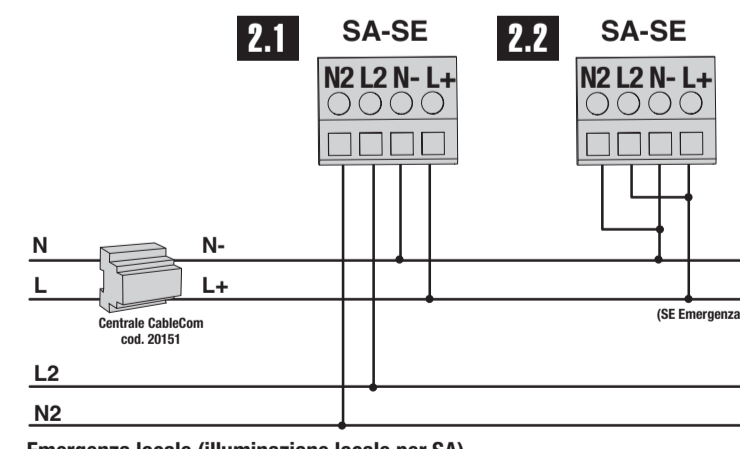
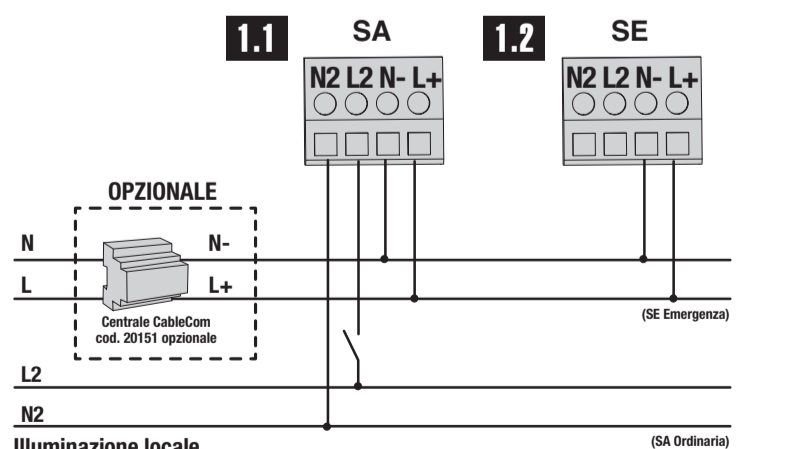

⚠ Per il funzionamento consultare anche i manuali della Centrale CableCom Connect (cod. 20151).
Per la configurazione da Centrale le batterie devono essere sufficientemente cariche.
Attenzione a NON invertire la polarità di fase e neutro. Lampade collegabili massimo 32.
Non collegare altri tipi di apparecchi sul cavo di alimentazione/BUS L+ N-.

For the functioning please refer to the instruction manuals either of the Central CableCom Connect (cod. 20151).

⚠ For the Central configuration the batteries must be sufficiently charged.
Be careful NOT to invert the phase and neutral polarity. Maximum connectable lamps 32.
Do not connect other types of devices on the power cable / BUS L+ N-.

Schema 2.1 L'apparecchio va in emergenza per:
- mancanza rete emergenza generale (rete CableCom);
- mancanza rete illuminazione locale

Schema 2.2 L'apparecchio va in emergenza per:
- mancanza rete emergenza generale (rete CableCom).

Attenzione:
Gli apparecchi SA possono essere impostati SE solo tramite App (con flash da smartphone sulla lampada o via wi-fi con Centrale CableCom Connect).
Con Infinity mode attivo i morsetti N2 L2 devono essere sempre connessi come negli schemi 2.1 o 2.2.

Wiring 2.1 The appliance goes into emergency conditions for:
- absence of a general emergency electricity (CableCom);
- absence of a local lighting

Wiring 2.2 The appliance goes into emergency conditions for:
- absence of a general emergency electricity (CableCom).

Caution:
SA luminaires can be set SE only through the App (with smartphone flash on the lamp or with wi-fi with Central CableCom Connect).
With Infinity mode on N2 L2 must be connected like wiring 2.1 or 2.2.

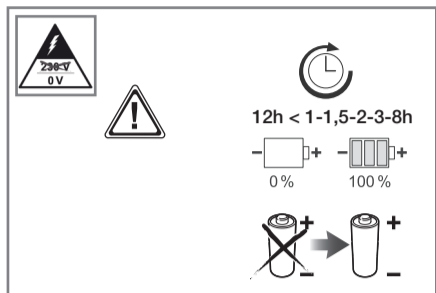
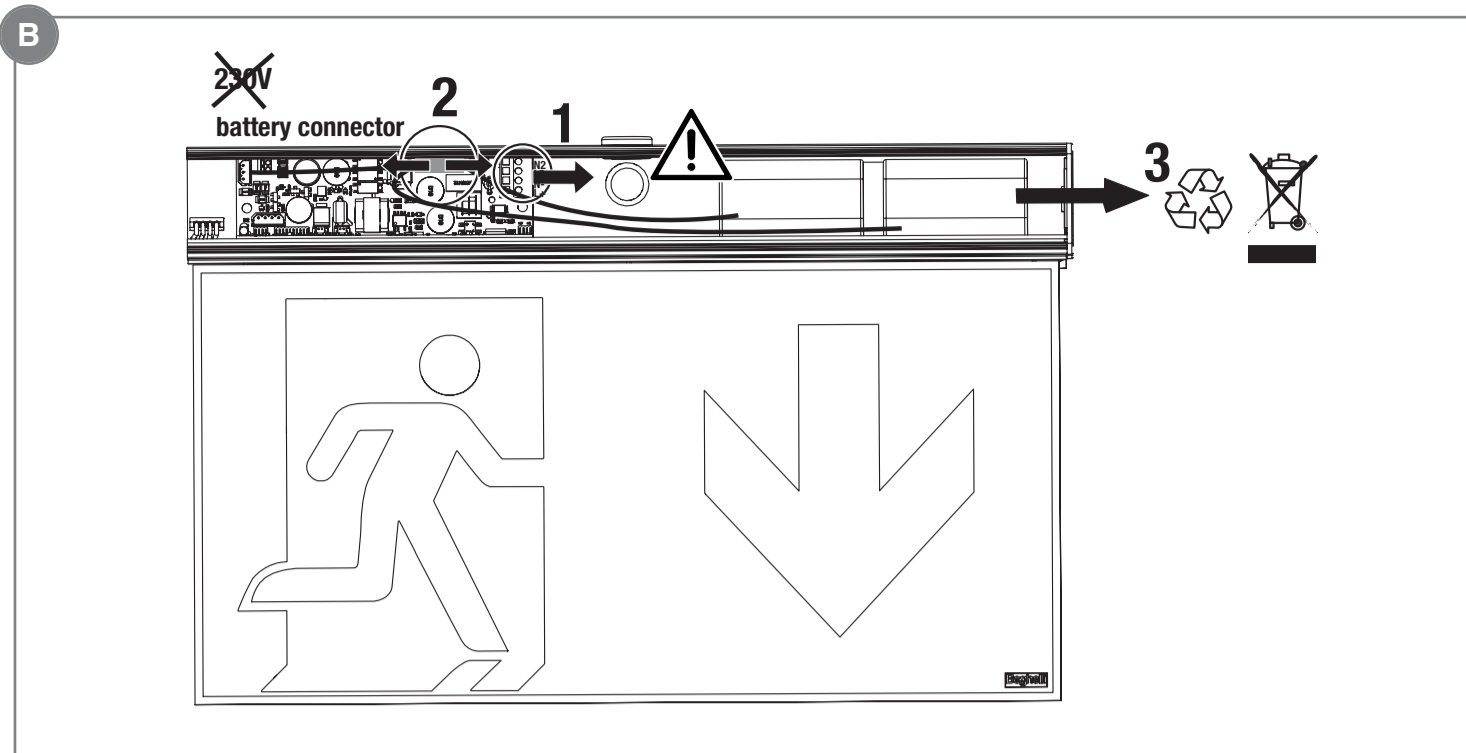
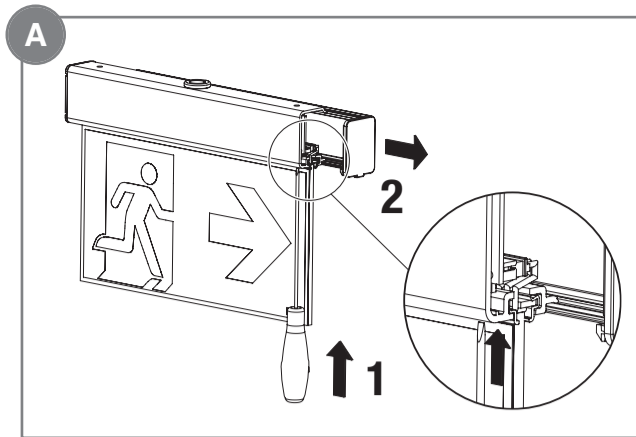

	230V 50Hz	COS φ	LED			
4382 (SE/SA)	33mA	0,53	72 LED	1h 1,5h 2h 3h 8h	2x LiFe 6,4V 0,6Ah	60m

* Per la gestione dell'autonomia fare riferimento alla tabella
For autonomy management refer to the table

Expansione con modulo LG • LGFM • DALI - Expansion with LG • LGFM • DALI module



SELV

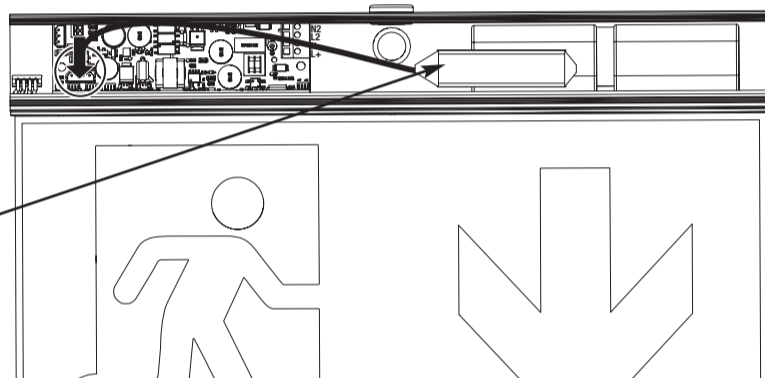

Modulo LG Cod. 15036
Modulo LG FM Cod. 15037
Modulo DALI Cod. 15038

• opzione disponibile - available option

CONFIGURAZIONI E COMANDI - CONFIGURATION AND COMMANDS	senza APP e senza Centrale without APP and without Central	Azione locale su singolo apparecchio Local action on a single device	Azione centralizzata Broadcasting action
		con APP	con CENTRALE CABLECOM CONNECT (cod. 20151)
Autonomia-Duration 1h	• Default	• Default	• Default
Autonomia-Duration 1,5h		•	•
Autonomia-Duration 2h		•	•
Autonomia-Duration 3h	• con jumper	•	•
Autonomia-Duration 8h		•	•
Settaggio SE/SA (solo su lampade SA) Setting Non-maintained/Maintained (only on Maintained Luminaire)		•	•
Settaggio pari/dispari AT / Setting even/odd AT	• Definito dall'ID del QR code. Non modificabile • Preset by ID of QR code. Cannot be modified	•	•
Durata Test 1h/ pari all'autonomia scelta / Test duration 1h or autonomy set	• Durata Test 1h • Test duration 1h	•	•
Settaggio Infinity mode / Setting Infinity mode	• Infinity mode disattivato di default • Infinity mode disabled by default	•	•
Rest Mode		•	•
Reset di fabbrica / Manufacturer data reset		•	•
Start/Stop Test Funzionale / Start/Stop functional Test		•	•
Start/Stop Test Autonomia / Start/Stop duration Test		•	•
Sync Test automatico / Sync automatic Test		•	•
Calendarizzazione Test automatico / Scheduling automatic Test			• Con partenza ritardata configurabile • With configurable delayed start • Con modifica periodicità • With change periodicity
Remotizzazione errore Failure report from remote place			• Tramite LED sulla Centrale; l'APP segnala quale lampada è in errore • By LED on Central; the APP indicates which lamp is in error
Localizzazione lampada / Luminaire tracking			•
Identificazione tipo lampada / Type of luminaire identification			•
LOGBOOK			•

Utilizzo con App B.connect - Use with App B.connect

- A- Aprire App B.connect (scaricabile su App Store e Google Play).
B- Tramite il menu "lampada" si accede alla configurazione della lampada.



- A- Open App B.connect (available for download on the App Store and Google Play).
B- The configuration of the lamp can be accessed through the "luminaire" menu.



RISPOSTA LAMPADA:

1 lampeggio alta luminosità= funzione eseguita
5 lampeggi bassa luminosità= funzione NON abilitata

Nessun lampeggio= comando NON ricevuto

N.B. Con centrale CableCom Connect cod 20151 tutte le configurazioni e i comandi possono essere inviate tramite da remoto tramite il cloud "nuBe".

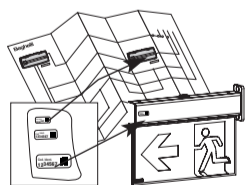

LAMP RESPONSE:

1 high brightness flash= function performed

5 low light flashes= function NOT enabled

No flashing= command NOT received

N.B. With CableCom Connect control unit cod 20151 all configurations and commands can be sent remotely via the "nuBe" cloud.

Su ogni apparecchio è presente un QR code che identifica univocamente la lampada.
On each device there is a QR code that uniquely identifies the lamp.

POSIZIONAMENTO LAMPADA PER COPERTURA APP B.connect
(es. molta luce - minore distanza)

POSITION LAMP FOR COVER ENSURE THE PROGRAM
(eg. a lot of light - less distance)

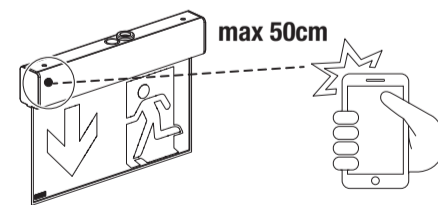

PERIODICITA' DEI TEST AUTOMATICI:

TEST FUNZIONALE (30 sec)= ogni 28 giorni
TEST DI AUTONOMIA (1h)= ogni 26 settimane
Le lampade pari eseguono il Test di autonomia 1 settimana dopo quelle dispari.
(0,2,...,8,A,C,E)= pari; (1,3,...,9,B,D,F)= dispari.

SEGNALAZIONI LED

VERDE FISSO BATTERIA CARICA
VERDE LAMPEGGIANTE BATTERIA IN RICARICA
UN LAMPEGGIO ROSSO ERRORE BATTERIA AUTONOMIA
DUE LAMPEGGI ROSSI ERRORE LED DI ILLUMINAZIONE
TRE LAMPEGGI ROSSI BATTERIA SCOLLEGATA

APERTURA DELLA COMUNICAZIONE DA APP:

Togliere e ridare la rete per meno di 3 secondi.

La comunicazione rimane possibile per 2 ore e per 1 min il LED lampeggia di arancione per segnalare l'apertura della comunicazione.

Test Funzionale e STOP Test funzionale sono comandati da App B.Connect in qualunque momento senza dover aprire la comunicazione con l'apparecchio.

AVVERTENZE - GARANZIA

- Questo apparecchio dovrà essere destinato solo all'uso per

il quale è stato costruito. Ogni altro uso è da considerarsi improprio e pericoloso.

- Batteria Ricaricabile e sorgente LED sono di tipo non sostituibile. Per eventuali riparazioni rivolgersi ad un centro di assistenza tecnica autorizzato e richiedere l'utilizzo di ricambi originali. Il mancato rispetto di quanto sopra può compromettere la sicurezza dell'apparecchio.

*** Attenzione: scossa elettrica

AUTOMATIC TESTS PERIODICITY:

FUNCTIONAL TEST (30 sec)= every 28 days
AUTONOMY TEST (1h)= every 26 weeks
Even lamps carry out the autonomy test 1 week after the odd lamps.
(0,2,...,8,A,C,E)= even; (1,3,...,9,B,D,F)= odd.

LED SIGNALS

FIXED GREEN BATTERY CHARGED
FLASHING GREEN BATTERY CHARGING
ONE RED FLASH BATTERY ERROR DURATION
TWO RED FLASHES LIGHTING LED ERROR
THREE RED FLASHES BATTERY DISCONNECTED

OPENING THE COMMUNICATION FROM APP:

Remove and reset the network for less than 3 seconds.

The communication remains possible for 2 hours and for 1 min the LED flashes orange to signal the communication opening. The Functional Test and the Functional STOP Test are controlled by the B.Connect App at any time without having to open communication with the device.

WARNINGS - GUARANTEE

- This device shall be used exclusively for the purpose for which it has been designed. Any other use is considered impro-

per and therefore dangerous.

- Rechargeable battery and LED source are non-replaceable type. Contact an authorised technical service centre for any repairs possibly required use only original spare parts. The lacked respect of the above conditions may compromise the safety of the device.

*** Caution: electric shock